



Power RF Amplifiers

Power = 40.0 Watts

Bandwidth = 20 to 512 Mhz

Gain = 37.0 dB Vdd =28.0 Volts

50 ohms Input/Output Impedance

Description

The MLCQ02 is a 40 Watt, high gain amplifier module covering a bandwidth of 20-512 Mhz. This compact module design is suitable for military applications in a rugged environment. An ALC pin is provided to control the output power, gain and blanking of the module.

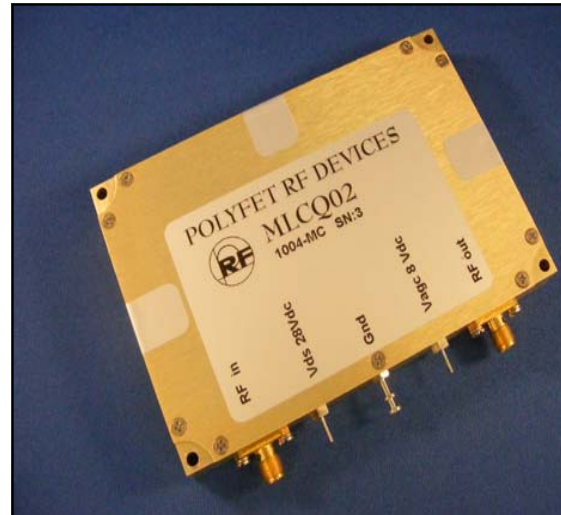

Absolute Maximum Ratings (T=25 °C)

Parameter	Symbol	Value	Unit
DC supply Voltage 1	VDD1	32.0	V
DC supply Voltage 2	VDD2		V
AGC Voltage	VAGC	8.5	V
AGC Current	VAGCI	2.50	mA
Input Power	Pin	0.025	W
Output Power	Pout	60.0	W
Operating Case Temp.	Tc	-40 to +85	°C
Storage Temperature	Tstg	-55 to +100	°C

Pin 1= RF in Pin 4=Vagc
 Pin 2= Vds Pin 5= RF out
 Pin 3= Gnd

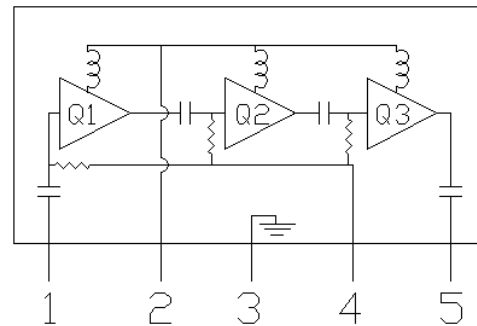

Electrical Characteristics: (T=25 °C Zs=Zl=50 ohms, Vdd = 28.0 Volts, Idq = 1.4 Amps)

Parameter	Symbol	Min	Typical	Max	Unit	Test Conditions
Frequency Range	BW	20		512	Mhz	50 ohm load
Output Power	Po	40.0			Watts	Pin = 10.0 dbm Vagc = 8.0 V
Power Gain	PG	37.0			dB	Pout = 40.0 Watts Vagc = 8.0 V
Total Efficiency	η		30		%	Pout = 40.0 Watts
2nd Harmonics	dso		-30.00		dBc	Pout = 40.0 Watts @ Mhz
Intermod - 2 tone	Im3		-15.00		dBc	AvePwr= 20.0 Watts
Load Mismatch Tolerance	VSWR	10:1			Relative	All Phase Angles Pout = 40.0Watts
Vagc Voltage	VAGC			8.0	V	Pin = 10.0 dBm, Pout = 40.0 W
Pulse Response Time	Pr			40.0	uS	Pulse source: RFin

MLCQ02

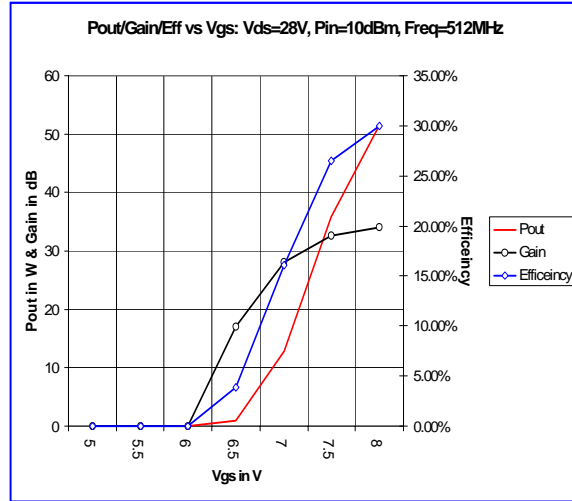
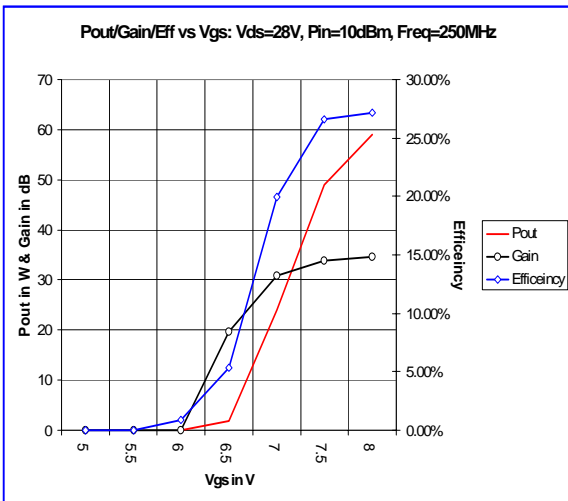
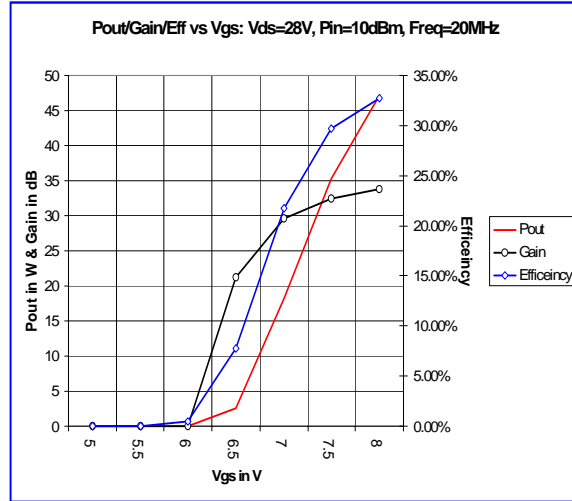
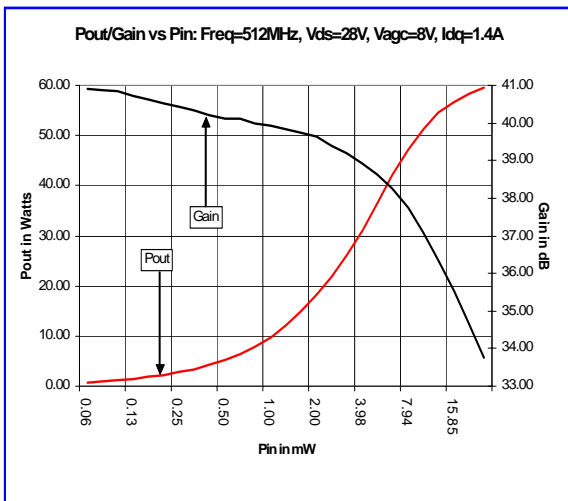
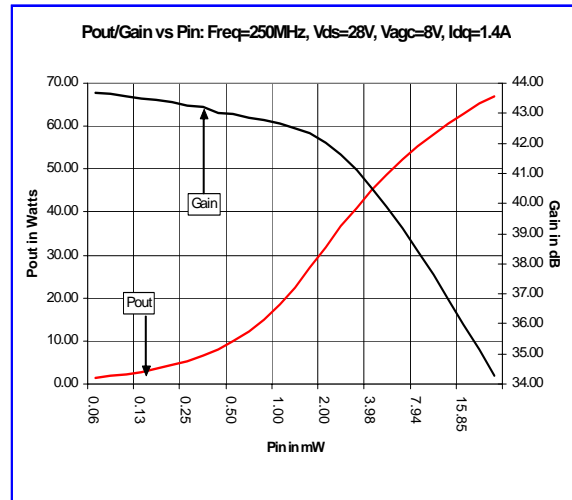
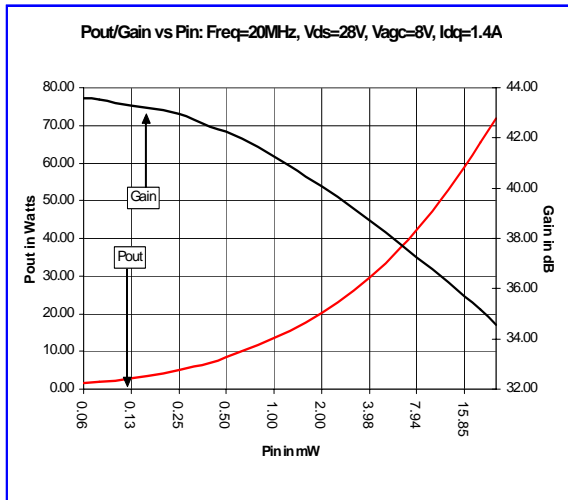

MLCQ02

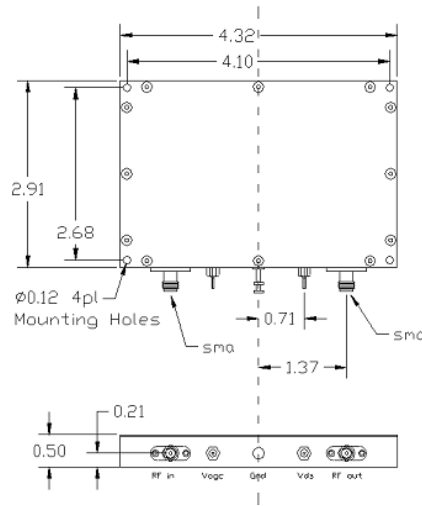
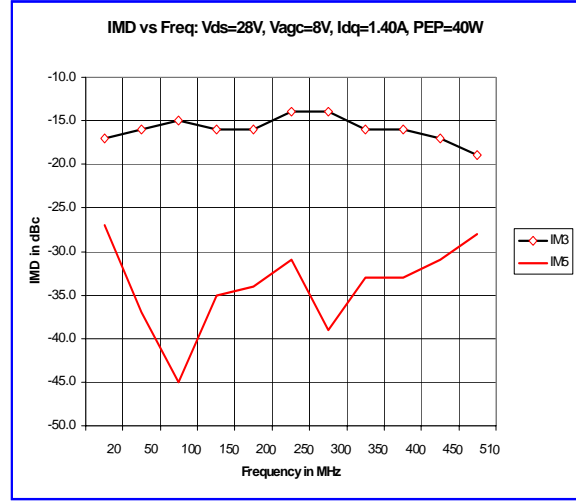
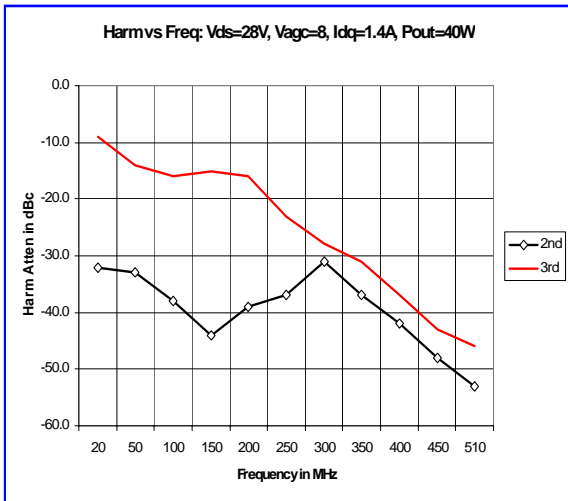
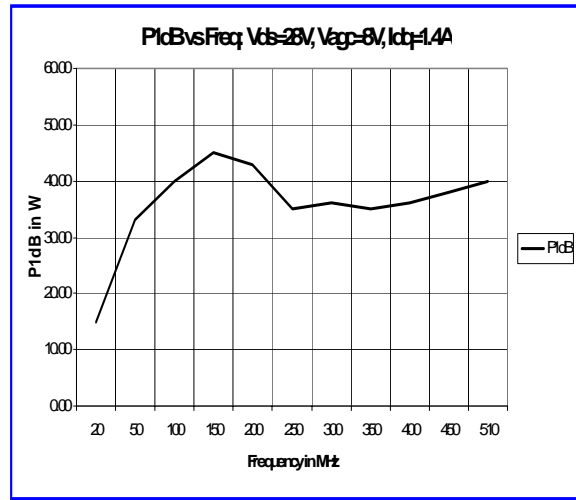
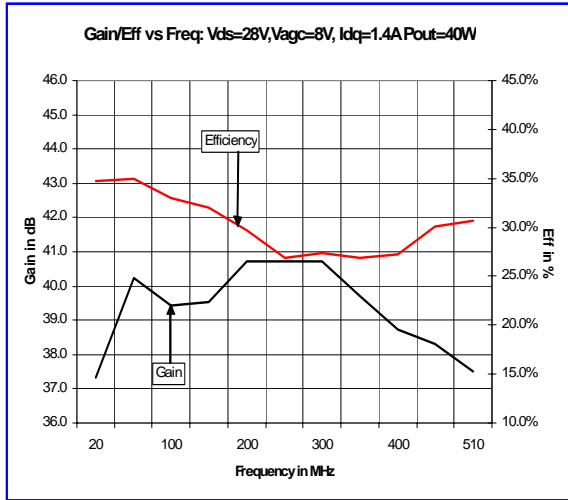

POLYFET RF DEVICES

REVISION 05/12/2010

1110 Avenida Acaso, Camarillo, Ca 93012 Tel:(805) 484-4210 FAX: (805) 484-3393 URL:www.polyfet.com