

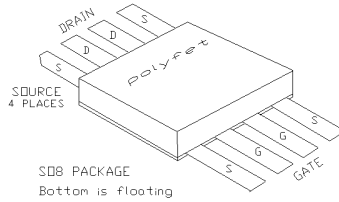

General Description

Silicon VDMOS and LDMOS transistors designed specifically for broadband RF applications. Suitable for Military Radios, Cellular and Paging Amplifier Base Stations, Broadcast FM/AM, MRI, Laser Driver and others.

"Polyfet"TM process features low feedback and output capacitances resulting in high F_t transistors with high input impedance and high efficiency.



**PATENTED GOLD METALLIZED
SILICON GATE ENHANCEMENT MODE
RF POWER VDMOS TRANSISTOR**

**1.0 Watts Single Ended
Package Style SO8**

**HIGH EFFICIENCY, LINEAR
HIGH GAIN, LOW NOISE**

ABSOLUTE MAXIMUM RATINGS ($T_C = 25^\circ C$)

Total Device Dissipation	Junction to Case Thermal Resistance	Maximum Junction Temperature	Storage Temperature	DC Drain Current	Drain to Gate Voltage	Drain to Source Voltage	Gate to Source Voltage
10 Watts	15.00 $^\circ C/W$	200 $^\circ C$	-65 $^\circ C$ to 150 $^\circ C$	0.8 A	50V	50V	30 V

RF CHARACTERISTICS (1.0 WATTS OUTPUT)

SYMBOL	PARAMETER	MIN	TYP	MAX	UNITS	TEST CONDITIONS
Gps	Common Source Power Gain	10			dB	$I_{dq} = 0.20$ A, $V_{ds} = 12.5$ V, $F = 850$ MHz
η	Drain Efficiency		50		%	$I_{dq} = 0.20$ A, $V_{ds} = 12.5$ V, $F = 850$ MHz
VSWR	Load Mismatch Tolerance			20:1	Relative	$I_{dq} = 0.20$ A, $V_{ds} = 12.5$ V, $F = 850$ MHz

ELECTRICAL CHARACTERISTICS (EACH SIDE)

SYMBOL	PARAMETER	MIN	TYP	MAX	UNITS	TEST CONDITIONS
Bvdss	Drain Breakdown Voltage	40			V	$I_{ds} = 0.01$ A, $V_{gs} = 0V$
I_{dss}	Zero Bias Drain Current			0.2	mA	$V_{ds} = 12.5$ V, $V_{gs} = 0V$
I_{gss}	Gate Leakage Current			1	μA	$V_{ds} = 0V$ $V_{gs} = 30V$
V_{gs}	Gate Bias for Drain Current	1		7	V	$I_{ds} = 0.02$ A, $V_{gs} = V_{ds}$
gM	Forward Transconductance		0.2		Mho	$V_{ds} = 10V$, $V_{gs} = 5V$
Rdson	Saturation Resistance		2.00		Ohm	$V_{gs} = 20V$, $I_{ds} = 1.60$ A
I_{dsat}	Saturation Current		2.30		Amp	$V_{gs} = 20V$, $V_{ds} = 10V$
Ciss	Common Source Input Capacitance		7.5		pF	$V_{ds} = 12.5$ $V_{gs} = 0V$, $F = 1$ MHz
Crss	Common Source Feedback Capacitance		1.2		pF	$V_{ds} = 12.5$ $V_{gs} = 0V$, $F = 1$ MHz
Coss	Common Source Output Capacitance		8.0		pF	$V_{ds} = 12.5$ $V_{gs} = 0V$, $F = 1$ MHz

P121

POUT VS PIN GRAPH

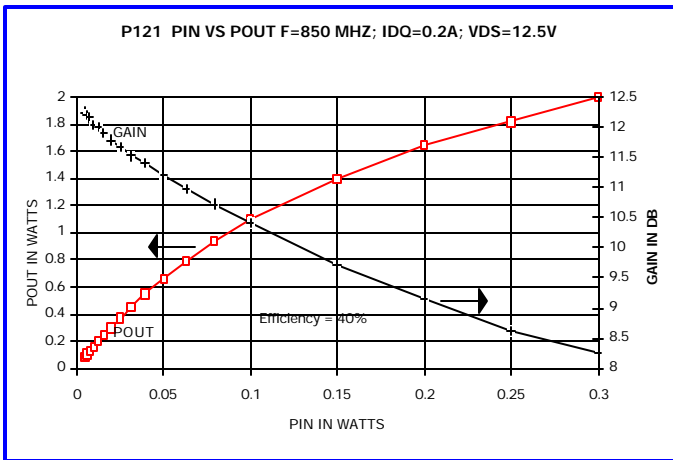

IV CURVE

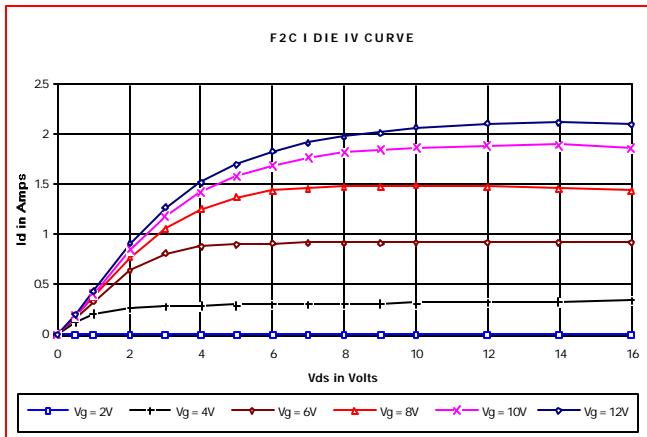

S11 & S22 SMITH CHART

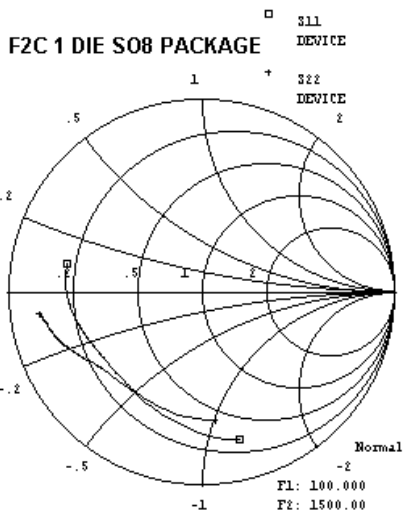

CAPACITANCE VS VOLTAGE

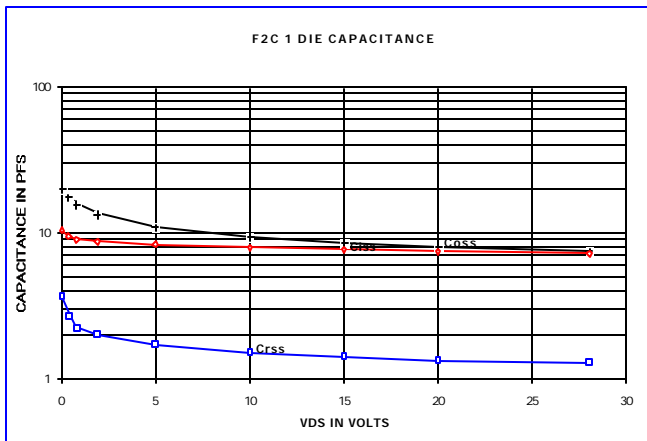

ID & GM VS VGS

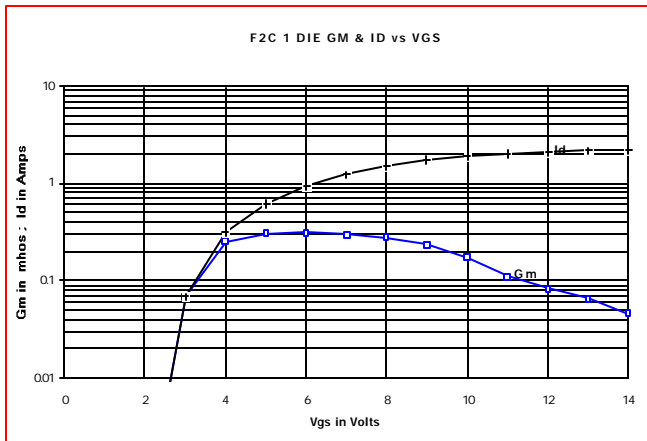

PACKAGE DIMENSIONS IN INCHES

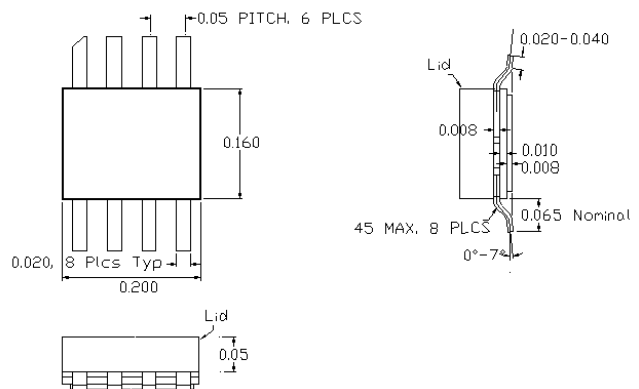

S08 / S08 -1

Tolerance .XX +/-0.01 .XXX +/- .005 inches