

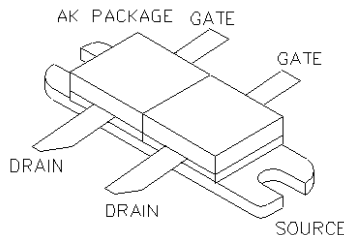

General Description

Silicon VDMOS and LDMOS transistors designed specifically for broadband RF applications. Suitable for Military Radios, Cellular and Paging Amplifier Base Stations, Broadcast FM/AM, MRI, Laser Driver and others.

"Polyfet"TM process features low feedback and output capacitances, resulting in high F_T transistors with high input impedance and high efficiency.



SILICON GATE ENHANCEMENT MODE

RF POWER LDMOS TRANSISTOR

70.0 Watts Push - Pull

Package Style AK

HIGH EFFICIENCY, LINEAR

HIGH GAIN, LOW NOISE

ROHS COMPLIANT

ABSOLUTE MAXIMUM RATINGS (T = 25 °C)

| Total Device Dissipation | Junction to Case Thermal Resistance | Maximum Junction Temperature | Storage Temperature | DC Drain Current | Drain to Gate Voltage | Drain to Source Voltage | Gate to Source Voltage |
|--------------------------|-------------------------------------|------------------------------|---------------------|------------------|-----------------------|-------------------------|------------------------|
| 150 Watts | 1.00 °C/W | 200 °C | -65 °C to 150 °C | 9.0 A | 70 V | 70 V | 20 V |

RF CHARACTERISTICS (70.0 WATTS OUTPUT)

| SYMBOL | PARAMETER | MIN | TYP | MAX | UNITS | TEST CONDITIONS |
|--------|--------------------------|-----|-----|------|----------|---|
| Gps | Common Source Power Gain | 14 | | | dB | Idq = 0.40 A, Vds = 28.0 V, F = 500 MHz |
| η | Drain Efficiency | | 55 | | % | Idq = 0.40 A, Vds = 28.0 V, F = 500 MHz |
| VSWR | Load Mismatch Tolerance | | | 10:1 | Relative | Idq = 0.40 A, Vds = 28.0 V, F = 500 MHz |

ELECTRICAL CHARACTERISTICS (EACH SIDE)

| SYMBOL | PARAMETER | MIN | TYP | MAX | UNITS | TEST CONDITIONS |
|--------|------------------------------------|-----|-------|-----|-------|--------------------------------|
| Bvdss | Drain Breakdown Voltage | 65 | | | V | Ids = 0.20 mA, Vgs = 0V |
| Idss | Zero Bias Drain Current | | | 2.0 | mA | Vds = 28.0 V, Vgs = 0V |
| Igss | Gate Leakage Current | | | 1 | uA | Vds = 0V Vgs = 30V |
| Vgs | Gate Bias for Drain Current | 2 | | 5 | V | Ids = 0.20 A, Vgs = Vds |
| gM | Forward Transconductance | | 1.6 | | Mho | Vds = 10V, Vgs = 5V |
| Rdson | Saturation Resistance | | 0.65 | | Ohm | Vgs = 20V, Ids = 8.00 A |
| Idsat | Saturation Current | | 10.00 | | Amp | Vgs = 20V, Vds = 10V |
| Ciss | Common Source Input Capacitance | | 60.0 | | pF | Vds = 28.0 Vgs = 0V, F = 1 MHz |
| Crss | Common Source Feedback Capacitance | | 1.6 | | pF | Vds = 28.0 Vgs = 0V, F = 1 MHz |
| Coss | Common Source Output Capacitance | | 30.0 | | pF | Vds = 28.0 Vgs = 0V, F = 1 MHz |

LK701

POUT VS PIN GRAPH

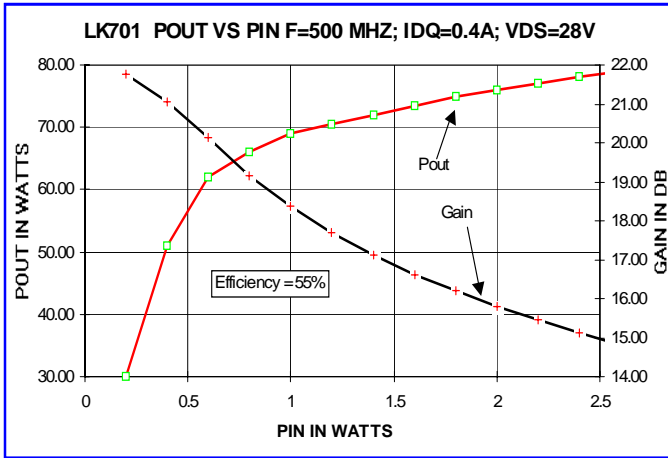

IV CURVE

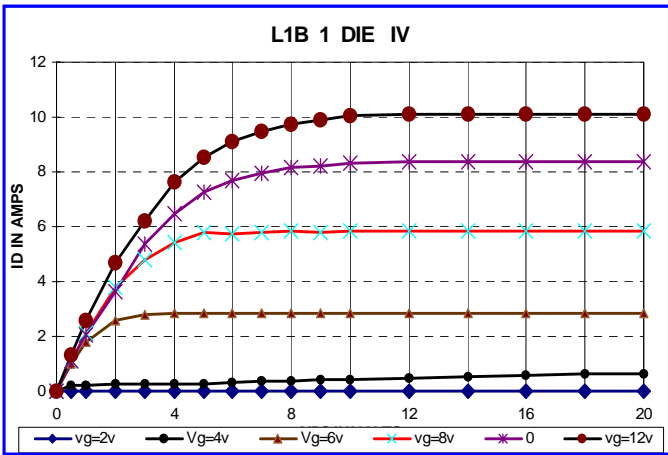

Zin Zout

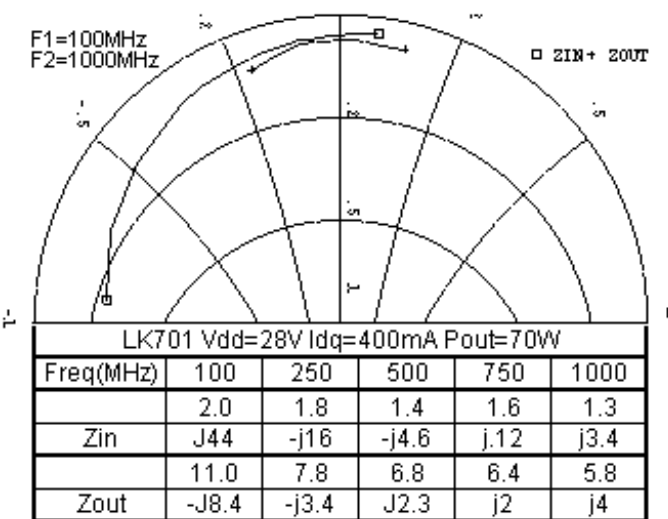

CAPACITANCE VS VOLTAGE

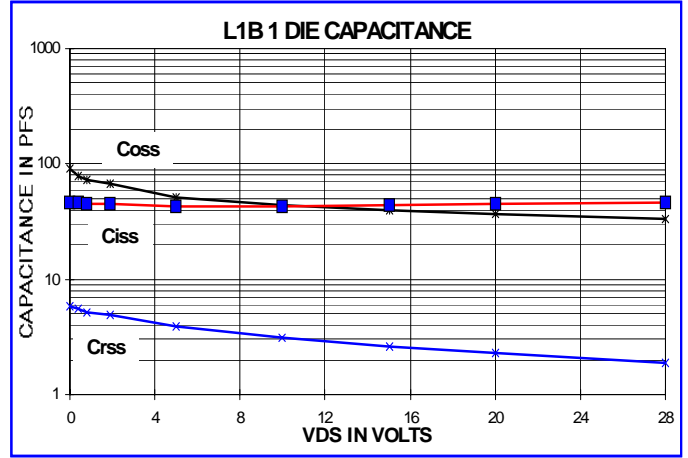

ID & GM VS VGS

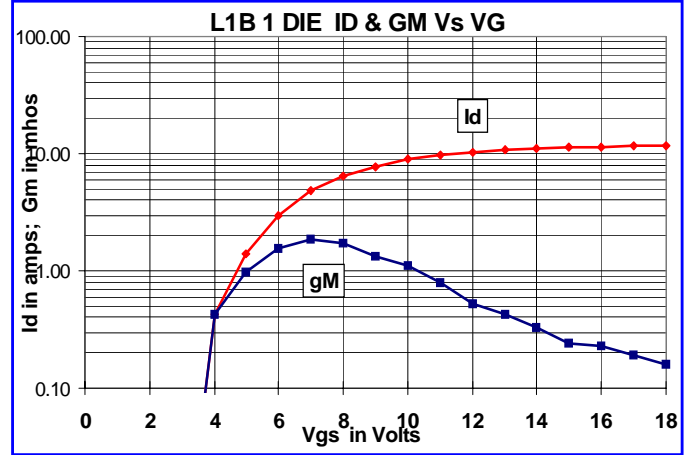

PACKAGE DIMENSIONS IN INCHES

